

Display over Ethernet Adapter

User's Manual

ABOUT THIS MANUAL

This manual is designed for use with the Display over Ethernet Adapter. Information in this document has been carefully checked for accuracy; however, no guarantee is given to the correctness of the contents. The information in this document is subject to change without notice. The manufacturer does not make any representations or warranties (implied or otherwise) regarding the accuracy and completeness of this document and shall in no event be liable for any loss of profit or any commercial damage, including but not limited to special, incidental, consequential, or other damage.

SAFETY INSTRUCTIONS

Always read the safety instructions carefully:

- Keep this User's Manual for future reference
- Keep this equipment away from humidity
- If any of the following situation arises, get the equipment checked by a service technician:
 - The equipment has been exposed to moisture.
 - The equipment has been dropped and damaged.
 - The equipment has obvious sign of breakage.
 - The equipment has not been working well or you cannot get it to work according to the User's Manual.

COPYRIGHT

This document contains proprietary information protected by copyright. All right are reserved. No part of this manual may be reproduced by any mechanical, electronic or other means, in any form, without prior written permission of the manufacturer.

TRADEMARKS

All trademarks and registered trademarks are the property of their respective owners or companies.

Table of Contents

1. Introduction	1
Features	1
Package Contents	2
System Requirements.....	2
LED Status	2
2. Installation	3
Hardware Connection	3
Driver Installation	4
On windows XP	4
On windows Vista	7
Display mode	10
3. Specifications	11
4. Regulatory Compliance	12
FCC Conditions	12
CE	12
WEEE Information	12

1. Introduction

This **DoIP (Display over IP) Adapter** enables you easily to connect one more monitor, LCD or projector to a computer over the Ethernet. Without the burden of opening the chase of PC, adding a graphics card and reconfiguring the system. You may easily have the high quality image presentation and DVD quality video playback. With the CAT5 cabling, you can place the remote display stations up to 100m away from the source. The Ethernet-attached solution provides a single DVI video port and design for small office, classrooms, exhibits, trade shows, monitor testing, demonstrations and multi-media presentations, etc....

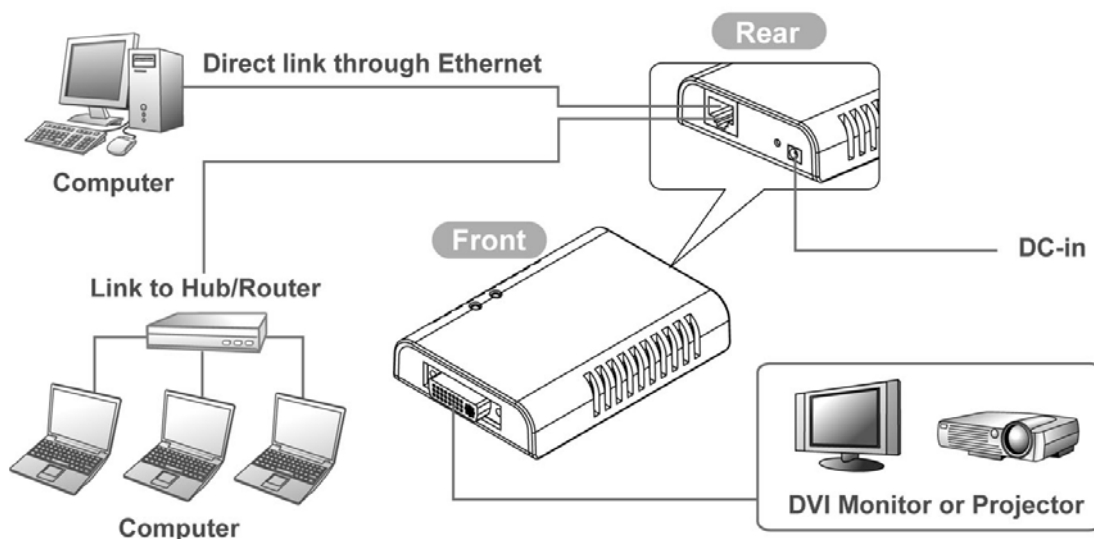

Features

- Add-on monitor, LCD or projector through Ethernet cable
- Video share through Ethernet
- Remote display device control
- Transfer distance up to 100 meter
- Window XP and Vista compatible

Package Contents

- Display over Ethernet Adapter x1
- Power Adapter x1
- RJ45 Ethernet Cable x1
- CD (Driver and User's Manual) x1
- Quick Installation Guide x1

System Requirements

- Windows XP 32-bit and Vista 32-bit
- DVI Monitor

LED Status

LED	Color	Description
Power	Red	On for connected to the power adapter Off for not connected to the power adapter
Link	Green	LAN activity. Blinking when there is data flow between LAN and the host computer

2. Installation

Hardware Connection

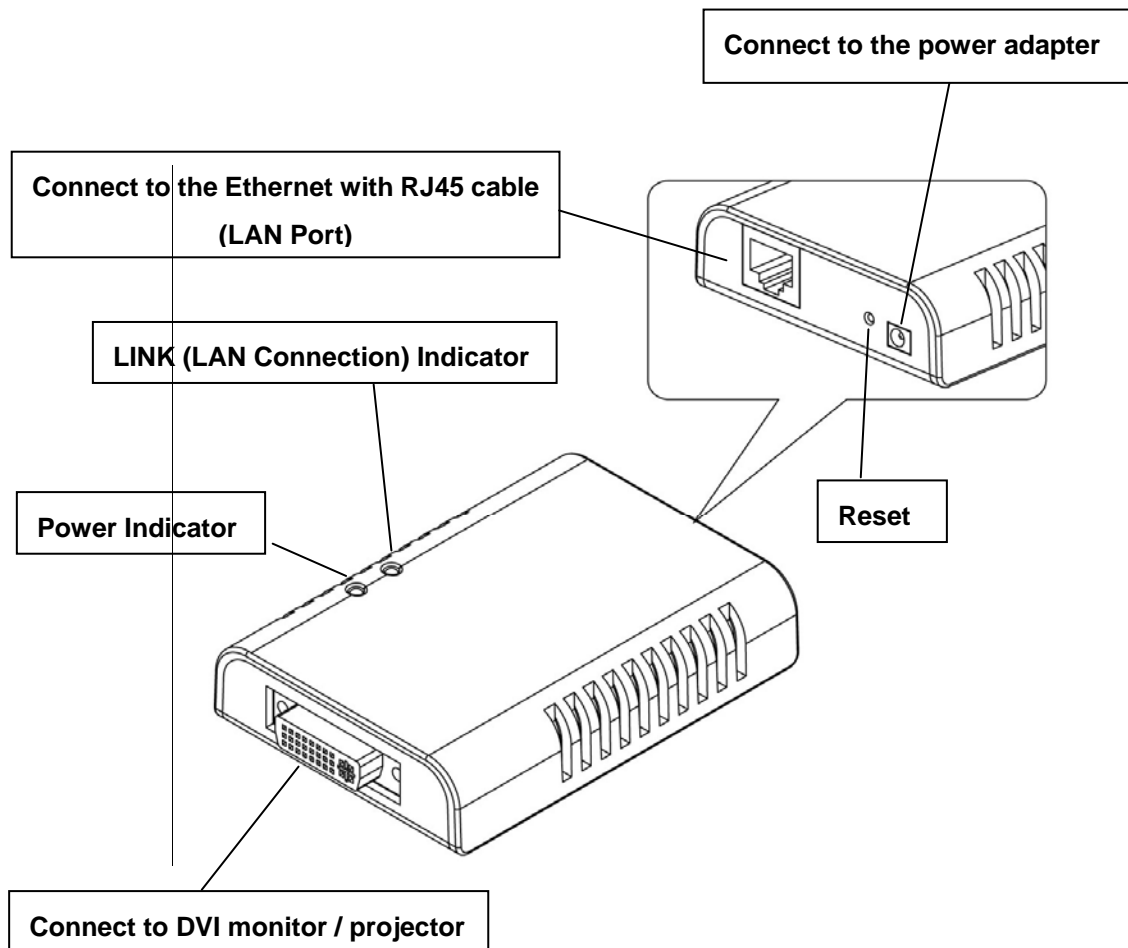

Driver Installation

On windows XP

Caution: DO NOT connect the adapter to your computer before installing the driver on the provide CD.

1. Insert the provided CD into your disc drive. Locate and double-click the **Setup.exe** file in the **Driver** folder to launch the setup program.

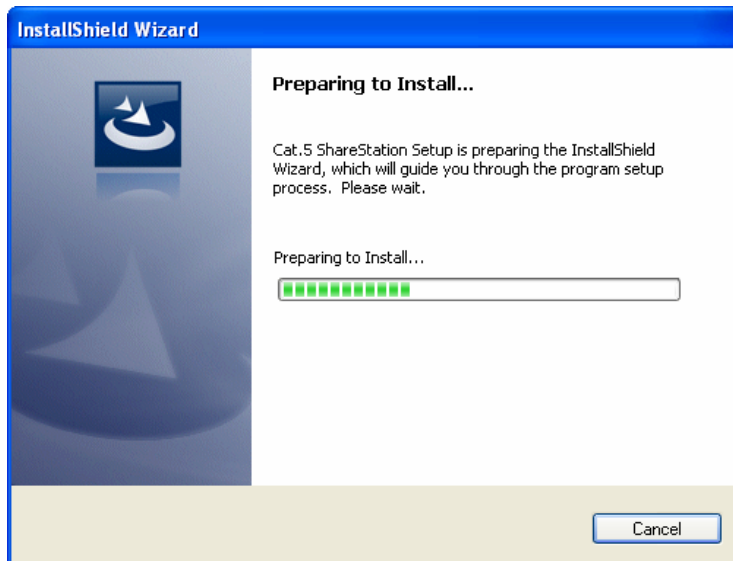

2. During the installation, the screen will flick black a couple of times. This is normal. When finished, the installation screen will disappear, and you can see the screen as below.

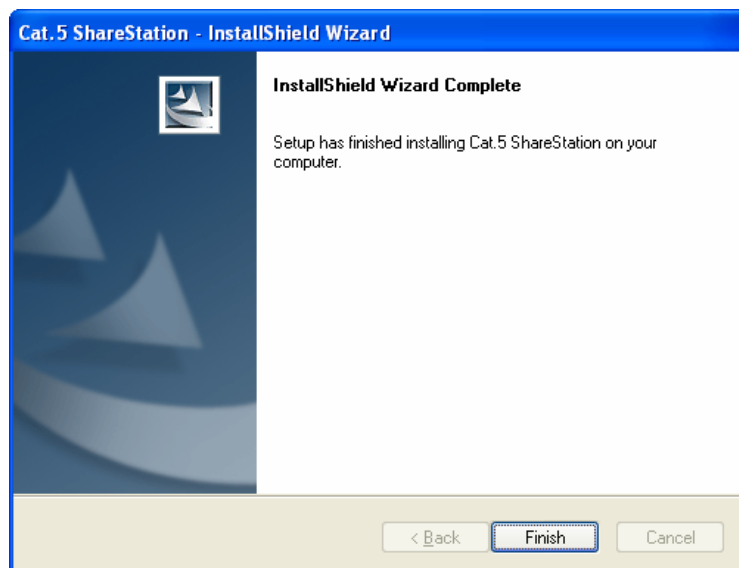

- When the **Install DisplayLink Software** screen appears, select I accept the terms in the license agreement.

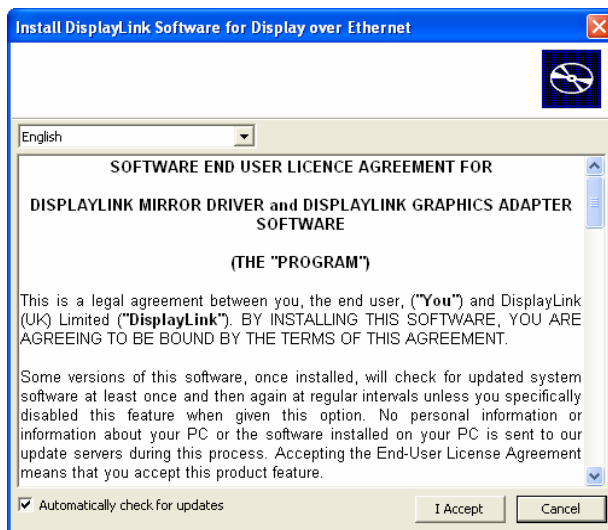

- When the **Windows Security Alert** screen appears, select **Unblock**. When finished, the installation screen will disappear and you will return to your desktop.
- Please **connect** the Ethernet adapter's LAN port end to a free Router.
- When the Found New Hardware Wizard screen appears, select **Install the software automatically (Recommended)** and click **Next**.



- Click **Finish** to complete the installation.



8. Please return to the desktop and Double-click the **Launch Cat5ShareStation.exe** icon on the desktop



9. Select **Generic DoIP** and double-click the **Connect** button, when the connection is ready, you will see the **Generic DoIP** icon become **orange** as below.

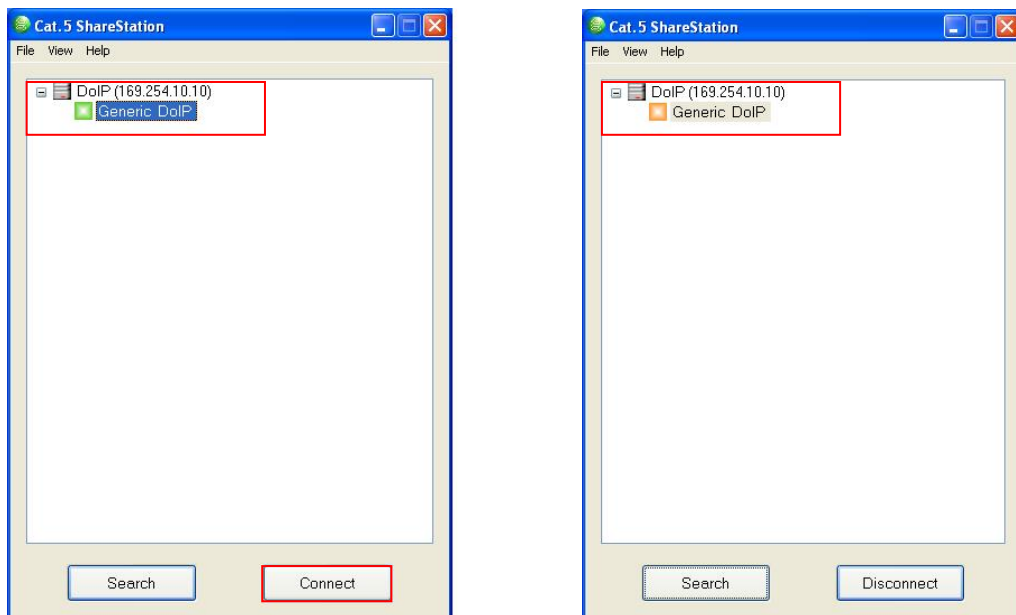

10. Then a pop-up message will appear in the notification area indicating the installation is complete.



11. If your monitor is not yet connected to the adapter, make the connection and power on your monitor.
12. After the connection, the adapter-attached monitor will soon be vivid and mirror your Windows desktop.

On windows Vista

Caution: DO NOT connect the adapter to your computer before installing the driver on the provide CD.

1. Insert the provided CD into your disc drive. Locate and double-click the **Setup.exe** file in the **Driver** folder to launch the setup program.

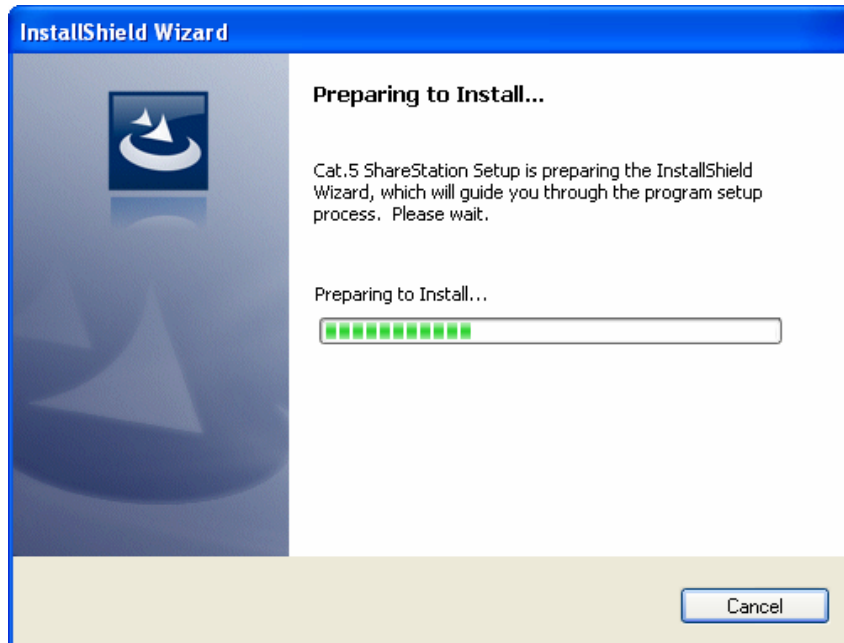

2. During the installation, the screen will flick black a couple of times. This is normal. When finished, the installation screen will disappear, and you can see the screen as below.

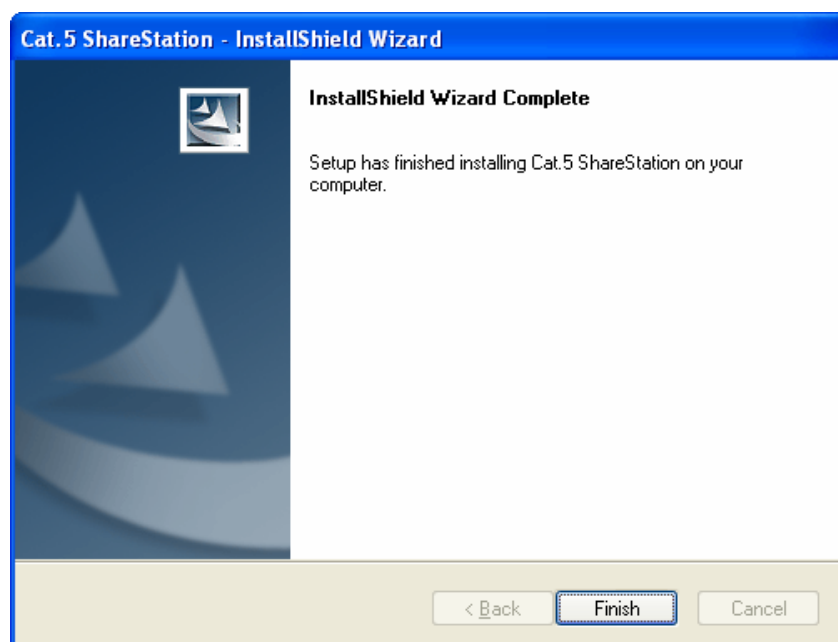

3. When the **Install DisplayLink Software** screen appears, select I accept the terms in the license agreement. After installed, select Yes to **restart** your computer and effect the Display over Ethernet driver

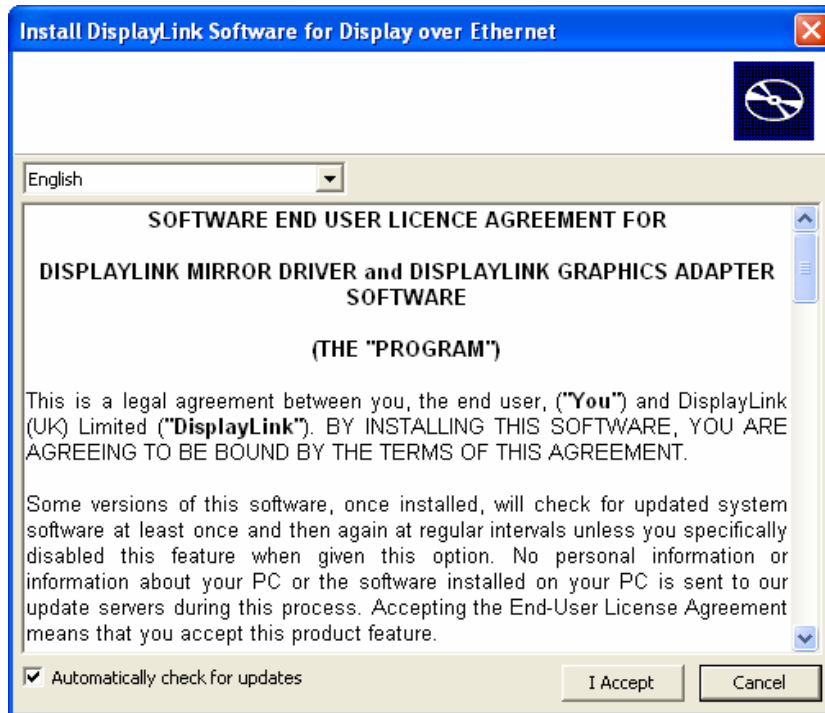

4. Then the installation of **Display Core Software** is running and to select **Yes** to restart your computer.

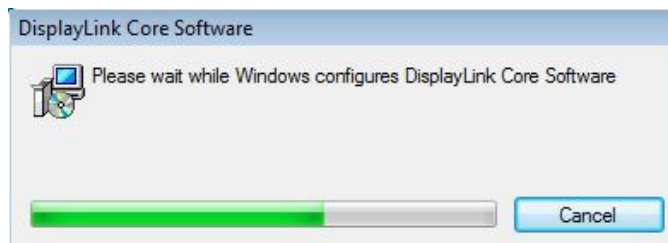

5. Please **connect** the Ethernet adapter's LAN port end to a free Router.
6. Please return to the desktop and Double-click the **Launch Cat5ShareStation.exe** icon on the desktop and click **unblock** when you see the **Security Alert**.

7. Select **Generic DoIP** and double-click the **Connect** button, when the connection is ready, you will see the **Generic DoIP** icon become **orange** as below.

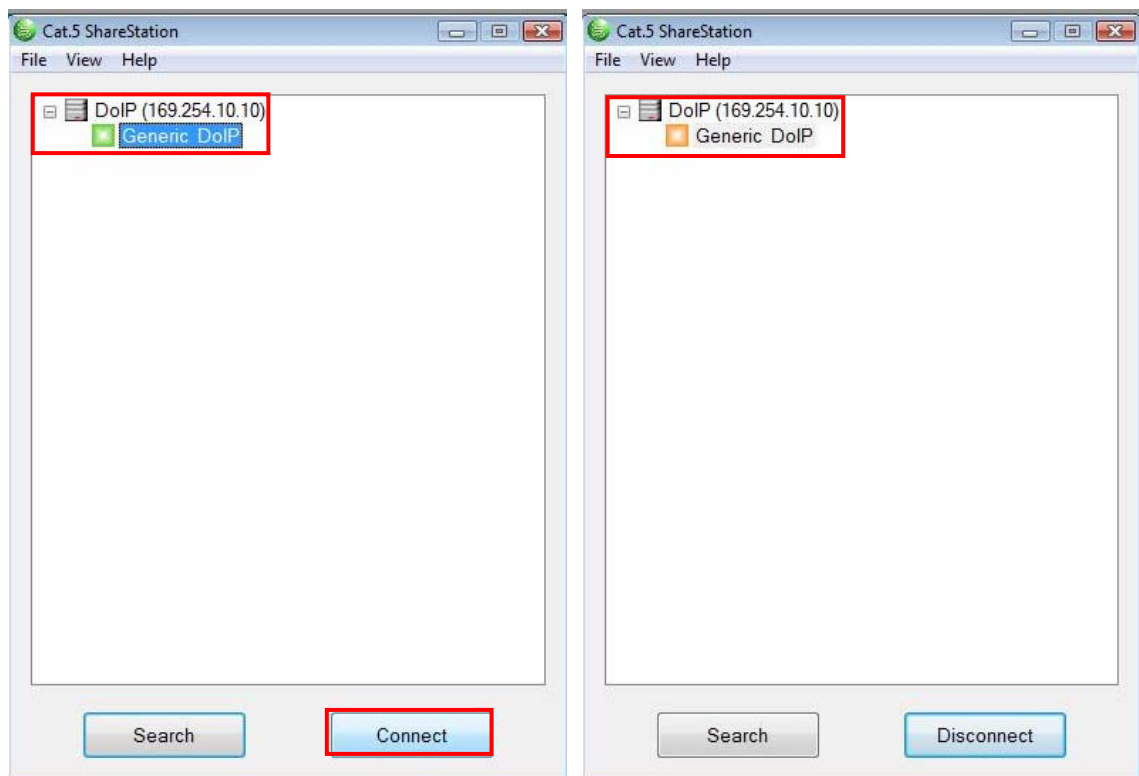

8. A pop-up message will appear in the notification area indicating the installation is complete.

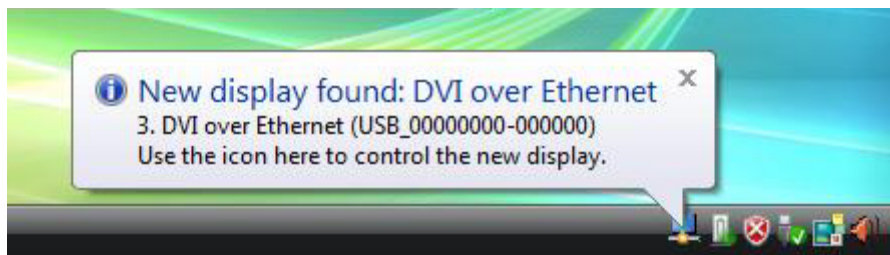

9. If your monitor is not yet connected to the adapter, make the connection and power on your monitor.
10. After the connection, the adapter-attached monitor will soon be vivid and mirror your Windows desktop.

Display mode

To change the display mode, right-click on your desktop and click **Properties > Settings**. Then select the monitor on USB display adapter to make configurations as needed.

The USB-attached monitor can be configured to:

- Extend your Windows desktop (default)
- Extend your Windows desktop to Right / Left / Above / Below
- Mirror your Windows desktop

On Windows XP

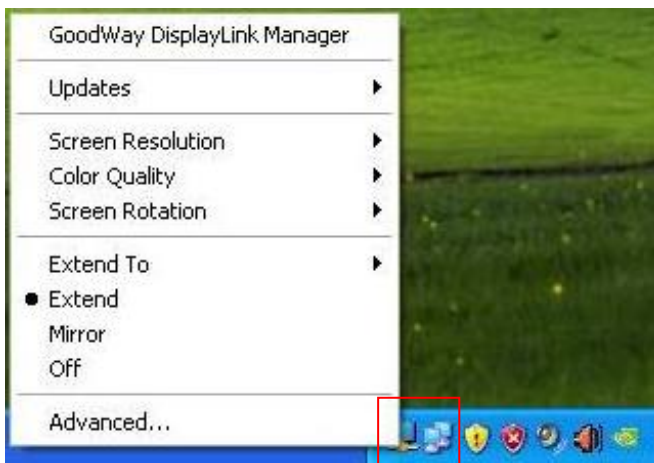

On Windows Vista

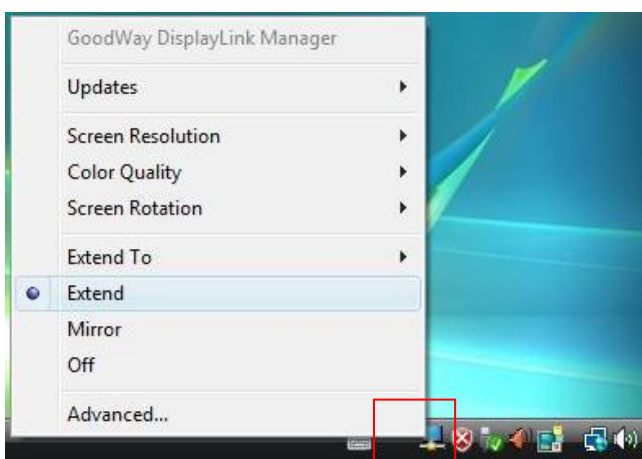

3. Specifications

ITEM	Description
Connectors	<ul style="list-style-type: none"> ■ LAN input : RJ-45 Connector ■ Video output : DVI-I 24pin + 5pin Female Connector
Power Mode	Self-powered (only)
Operation System Support	Windows XP 32-bit and Vista 32-bit
Power Mode	<ul style="list-style-type: none"> ■ AC input : 100~240V - 50Hz~60Hz ■ DC output : 5V / 2.5A
Supported Modes	<ul style="list-style-type: none"> ■ Extended Desktop (Default) ■ Extended to Right / Left / Above / Below Desktop ■ Mirrored Desktop
Resolutions	Max to 1280 x 1024
Supported colors	16 Bits and 32 Bits
LED Ports	<ul style="list-style-type: none"> ■ One red LED for power on indication ■ One green LED for LAN activity indication
Working Environment:	<ul style="list-style-type: none"> ■ Operation temperature: 10 ~ 40 degree ■ Storage temperature: -10 ~ 80 degree
Dimension & Weight	69.8(W) x 97(L) x 20.8(H) mm ; 83g
Housing	Plastic
Safety Requirement	CE, FCC

*Specifications are subject to change without further notice

4. Regulatory Compliance

FCC Conditions

This equipment has been tested and found to comply with Part 15 Class B of the FCC Rules. Operation is subject to the following two conditions:

- (1) This device may not cause harmful interference
- (2) This device must accept any interference received. Including interference that may cause undesired operation.

CE

This equipment is in compliance with the requirements of the following regulations: EN 55 022: EMC Directive 2004/08/EC (EN55022/EN55024)

WEEE Information

For EU (European Union) member users:

According to the WEEE (Waste electrical and electronic equipment) Directive, do not dispose of this product as household waste or commercial waste. Waste electrical and electronic equipment should be appropriately collected and recycled as required by practices established for your country. For information on recycling of this product, please contact your local authorities, your household waste disposal service or the shop where you purchased the product.

